



INDUSTRIAL DOORS



- ✓ ALL DOOR ELEMENTS ARE DEVELOPED TAKING INTO ACCOUNT CLIMATIC CONDITIONS
- ✓ DOORS MEET THE HIGHEST QUALITY STANDARDS



We offer you a series of industrial sectional doors, made by DoorHan.



QUALITY IN DETAIL

ENERGY CONSERVATION



The special structure of DoorHan industrial doors make them energy-saving, which allows you to conserve space heat and microclimate, and also to reduce heat losses and costs for room heating.

STRENGTH



Due to materials, used for production of DoorHan industrial doors, they possess increased strength and can withstand severe wind loads.

AIRTIGHTNESS

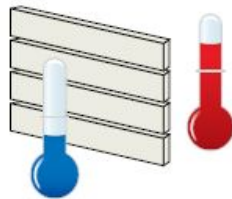

The door leaf structure and the sealing system increase door airtightness. Space behind the doors is not subjected to draught and sudden temperature fluctuations. It is extremely essential for spaces, where products are warehoused, and for which storage it is necessary to preserve the microclimate.

ACOUSTIC INSULATION

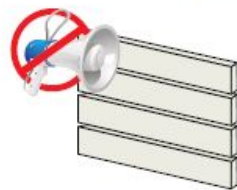

Industrial doors possess not only the thermal-insulating properties, but also sound-proofing ones - they prevent the penetration of sound from the street.

PRODUCTION

WORTHY OF YOU QUALITY

DoorHan organized the full cycle production of industrial sectional doors. Due to this, we answer for the product quality. High operational characteristics of our industrial doors are laid down already at the design stage. The work of the company's specialists allows it to develop doors oriented to any conditions – a large fluctuation range of seasonal temperatures and other specific features.



02

Our production is an embodiment of modern technologies and materials. We are constantly improving and developing, moving with the times and offering doors, meeting the modern requirements.



Leaders of their professions work in our company at all stages: from doors designing to their installation. We take care of our workers' qualification, as their responsibility and professionalism are our guarantee of product and service quality.

All component parts of DoorHan industrial doors are made on the certified world-level equipment. All door constituents pass tests for compliance to world standards.



In modern world high demands are placed on ecological cleanness of manufacturing and products. Therefore DoorHan uses ecologically pure and high-quality materials.



Our industrial sectional doors are designed for high intensity and long service life; that is why we use high-quality materials: modern superalloys and paint materials from leading world producers.



At your desire it is possible to paint panels into any color as per the international RAL card. During printout the colors can be distorted, please use the original RAL card.

DoorHan offers a rich selection of color solutions for industrial doors. The absolute advantage is not only a wide choice of colors, but the quality of paint materials. Sandwich-panels and aluminium sections are factory-painted at the specialized paint lines.

PANORAMIC DOORS

DoorHan industrial panoramic doors are a unique solution for projects, where it is required to provide maximum view of inner or outer space. Industrial panoramic doors are a modern design solution, which will decorate the front. If it is necessary to ensure the increased light transmission capability of the doors, DoorHan offers fully-glazed doors.

Due to their special structure, DoorHan panoramic doors conserve heat and do not freeze in joints; they are corrosion-proof and preserve their attractive appearance for a long time. The panoramic door leaf can be combined with a sandwich panel. This allows you to augment thermal-insulating properties of the doors. Besides the unequalled functional performance, DoorHan sectional panoramic doors are a functional solution for business.

When it is necessary to ensure the increased energy conservation, DoorHan offers industrial panoramic doors, made of panels with aluminium section "T-bridge". T-bridge is a system of aluminium sections with thermal insert, made of high-strength material - polyamide. The application of the given system allows you to protect panoramic doors against freezing, having considerably reduced costs for space heating.

It is possible to fit a wicket into DoorHan sectional panoramic doors; this allows you to get into the room, when the doors are closed. Owing to the sealing system, when the wicket is imbedded, DoorHan doors do not lose their thermal-insulating properties. All wickets are equipped with a door closer, which eases the use of the wicket.

FULLY-GLAZED PANORAMIC DOORS WITH LINTELS

VERSIONS OF INDUSTRIAL SECTIONAL DOORS ISD 02

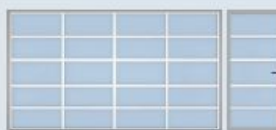

Fully-glazed doors + entrance door

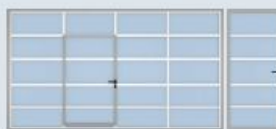

Fully-glazed doors with pass door + entrance door

Glazed panoramic panels of aluminium sections form a door leaf.

Doorway dimensions:
Dimensions of cell light:
width: 2,000 – 6,000 mm; **height:** 2,000 – 6,000 mm;
height: from 370 to 650 mm; **width:** maximum 3,000 mm
Intel height: minimum 150 mm;
 (with vertical lift and leaf width equal to 4.5 – 6 m,
distance from doorway edge to wall: minimum 140 mm;

light width - maximum 900 mm).
room depth: door leaf height plus 500 mm.
Installation of composite panels into any doorway
Room dimensions:
Instead of Insulated glazing unit material is possible.
width: from 600 to 1,500 mm, **height:** from 1,100 to 2,500 mm;

04



VERSIONS OF INDUSTRIAL SECTIONAL DOORS ISD 02

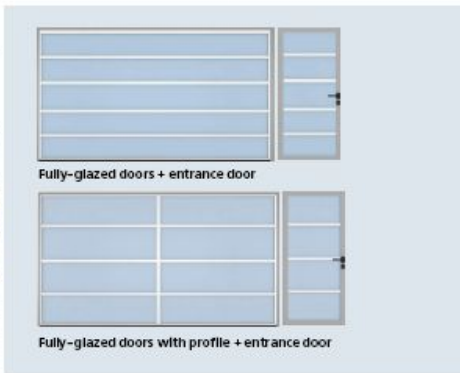

Glazed panoramic panels of aluminum sections form a door leaf.

Doorway dimensions: width: 2,000 – 6,000 mm; height: 2,000 – 8,000 mm; **lintel height:** minimum 150 mm; **distance from doorway edge to wall:** minimum 140 mm; **room depth:** door leaf height plus 500 mm.
Room dimensions: width: from 600 to 1,500 mm, height: from 1,100 to 2,500 mm;

Dimensions of cell light: height: from 370 to 650 mm; width: maximum 3,000 mm (with vertical lift and leaf width equal to 4.5 - 6 m, light width - maximum 900 mm). **Installation of composite panels into any doorway instead of insulated glazing unit material is possible.**

COMBINED PANORAMIC DOORS

VERSIONS OF INDUSTRIAL SECTIONAL DOORS ISD 02

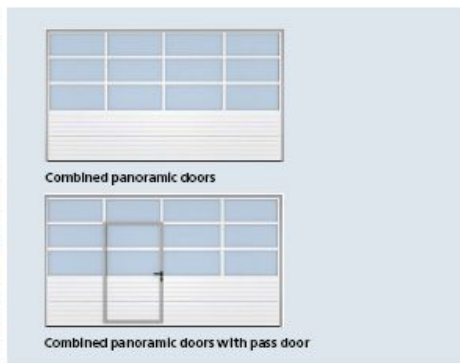

Glazed panoramic panels of aluminum sections form a door leaf.

Doorway dimensions:
Dimensions of cell light:
width: 2,000 – 6,000 mm; **height:** 2,000 – 8,000 mm;
height: from 370 to 650 mm; **width:** maximum 3,000 mm
lintel height: minimum 150 mm;
(with vertical lift and leaf width equal to 4.5 – 6 m,
distance from doorway edge to wall: minimum 140 mm;

light width - maximum 900 mm).
room depth: door leaf height plus 500 mm.
Installation of composite panels into any doorway
Room dimensions:
instead of insulated glazing unit material is possible.
width: from 600 to 1,500 mm, height: from 1,100 to 2,500 mm;

INDUSTRIAL SECTIONAL PANORAMIC DOORS ISD02



04

DoorHan panels for sectional panoramic doors consist of special aluminium sections and glazing. Materials resistant to mechanical effects - polycarbonate, impact-resistant polycarbonate or louvered organic glass, can be used as glazing. These materials possess high resistance to impact and also have a special coating, excluding weeping of the insulated glazing unit. The special construction of aluminium section, which is used in panoramic panels, ensures high strength and reliability of the structure. For increasing thermal-insulating properties of its doors, DoorHan offers to combine panoramic and sandwich panels.



PANORAMIC PANEL WITH ALUMINIUM SECTION SYSTEM T-BRIDGE

T-BRIDGE SYSTEM



POLYCARBONATE, IMPACT-RESISTANT POLYCARBONATE, LOWELED ORGANIC GLASS

T-BRIDGE SYSTEM



ALUMINIUM SECTION



At your desire it is possible to paint panels into any color as per the international RAL card. During printout the colors can be distorted, please use the original RAL card.

TECHNICAL PARAMETERS

Wind load	5 class (200 km/h)
Waterlightness	1 class (water pressure 30 Pa)
Lifting force	up to 40 kg
Door leaf weight	17 kg/m ²

PANORAMIC PANEL

ALUMINIUM SECTION

POLYCARBONATE, IMPACT-RESISTANT POLYCARBONATE, LOWELED ORGANIC GLASS



At your desire it is possible to paint panels into any color as per the international RAL card. During printout the colors can be distorted, please use the original RAL card.

TECHNICAL PARAMETERS

Wind load	5 class (200 km/h)
Waterlightness	1 class (water pressure 30 Pa)
Lifting force	up to 40 kg
Door leaf weight	17 kg/m ²

Should there be an order for doors made of louvered organic glass, you can choose from several glazing colors. Such stylish solution will advantageously single out the front and attract attention of potential customers to it. Besides, sections can be painted any color as per RAL card; this will allow you to make panoramic doors in one color solution with building facade or interior.



AUTOMATIC EQUIPMENT (OPERATORS AND ACCESSORIES)



COMFORT

Automatized systems make doors a modern high-tech product, which eases the door opening and closing process.

DOORHAN SHAFT OPERATOR



DoorHan shaft operator are an ideal solution for industrial doors of any type. Electric operators, model Shaft-30/60/120, are operators of shaft type with gear in "oil bath". This technology considerably increases the operator life and allows you to use it more intensively.

The operator consists of an electric motor and a mechanical gear, and also has a built-in control unit. A three-position control desk is connected to the control unit. When there is a power dump, a manual emergency release permits to open or to close the doors manually by means of a chain.

05

TRAFFIC LIGHTS



Traffic light is used as a signaling means for traffic handling. Its casing is made of high-quality plastic.

THREE-POSITION CONTROL DESK

The three-position control desk is designed for individual control of door motion with a separate button for door stopping.

TWO-POSITION CONTROL DESK WITH KEY-BUTTON

The two-position control desk with a key allows you to handle traffic and to prevent unauthorized door control.

REMOTE CONTROL PANELS

The remote control panels DoorHan Transmitter 4 are designed for controlling DoorHan automatic equipment or any other device, to which DoorHan radio receiver is connected. One can control four doors (barriers or other automatic devices) by one panel.

OPTOELECTRONIC SENSORS

The optoelectronic sensors Optokit include two infrared safety sensors - a receiver and a transmitter. Both sensors are laid in a molded rubber strip. When the molded rubber strip is deformed, the optical ray is interrupted and the signal is given to the control unit, which performs the stop or reversal of the doors.

KEY-BUTTON SWM

The key-button SWM is used for add-on assembly. It possesses the same properties as KEY-SWITCH. The key-button SWM is singled out by its reliability due to the metallic vandal-proof casing and the rear water-proof wall, which prevents moisture from penetrating into the casing. The key-button is easy to install and to connect.

RADIO CODE KEYPAD

The radio code cordless keypad is designed for control of the door electric drive, equipped with DoorHan built-in or external receiver. The control radio commands are issued only after the serial input of a programmed access code. The code keypad is easy to install and to adjust.

PHOTOELECTRIC DETECTORS

The photoelectric detectors PHOTOCCELL are designed for prediction of emergency situations, if foreign elements get into a doorway. In case of infrared ray crossing, the signal about appearance of an obstacle comes into the control unit, as a result of which the stop or reversal of the door leaf occurs.

KEY-BUTTON KEYSWITCH

The key-button KEYSWITCH allows you to send a signal for door opening, closing or stopping, by having turned the key. To end the command, release the key - it will return to its initial position. The key-button has a mechanical interlock, which does not allow you to remove a cover without the installed and turned key.

EXTERNAL RADIO RECEIVERS

The external radio receivers DHRE-2 are designed for controlling automatic equipment of other manufacturers by means of DoorHan panel. The connection to any operator is possible.

RICH CHOICE, OPTIMUM SOLUTION



Polycarbonate

Polycarbonate is used for panoramic door glazing; it possesses a number of advantages:

- high optical transparency;
- low weight;
- weather resistance.

TECHNICAL PARAMETERS

Thickness of Insulated glazing unit made of acryl	22 mm
Panel height is dynamically calculated on the basis of doorway height:	maximum value - 650 mm, minimum value - 370 mm
Maximum doorway width without lintel	900 mm
Maximum doorway width with lintel	6000 mm
Maximum panel section height	8000 mm

Impact-resistant polycarbonate



Impact-resistant polycarbonate possesses such unique properties as lightness, extreme transparency and resistance to damaging factors, including unfavourable weather conditions (even hail), and fire resistance, also it is convenient for assembly. The translucent panels with impact-resistant polycarbonate are 200 times stronger than glass. The strength of polycarbonate sheets is permanent under any weather conditions within the temperature range from -400 C to +1200 C. Besides, such panels possess the increased light transmission up to 91% and do not change their properties even if exposed to direct sunlight for a long time.

TECHNICAL PARAMETERS

Thickness of Insulated glazing unit made of Impact-resistant polycarbonate	22 mm
Panel height is dynamically calculated on the basis of doorway height:	maximum value - 650 mm, minimum value - 370 mm
Maximum doorway width without lintel	3190 mm
Maximum doorway width with lintel	6000 mm
Maximum panel section height	8000 mm

Louvered organic glass

Louvered glass, used for production of insulated glazing units in panoramic panels, is an extruded acrylic sheet (plexiglass), possessing unequalled resistance to weather conditions and high transparency (clear sheet: 92% light transmission). Due to inner fins in the louvered organic glass, panels possess the increased strength. Three types of the louvered organic glass with different transparency degrees, different dimensions of inner chambers and different tint coating are used.

ALLTOP

ALLTOP is a double-layer louvered sheet with large intervals between partitions (64 mm). ALLTOP has an anti-drop coating from both sides and inside cells. Due to this, the light transmission is increased up to 91%; the condensate on inner and outer surfaces remains practically invisible. The use of ALLTOP in the panoramic door leaf contributes to the increase of energy conservation.

HEATSTOP

HEATSTOP is a double-layer louvered sheet, reflecting infrared radiation, made of impact-modified polymethylmethacrylate (PMMA). The coating HEATSTOP is equally distributed and integrated into the sheet volume on this louvered sheet. HEATSTOP possesses high toughness in comparison with common louvered organic glass. This material has an anti-drop coating, on which a special protective layer is applied.

RESIST

RESIST 00721
RESIST W1621

RESIST is a double-layer translucent, heat-insulating louvered sheet with high weather resistance, made of impact-modified polymethylmethacrylate (PMMA). This material is used for glazing, when the exceptional strength in combination with the construction lightness is required. DoorHan offers two options of filling RESIST, differed by light conductivity: RESIST W1621 - 74% light transmission, and RESIST 00721 - 85% light transmission.

TECHNICAL PARAMETERS

Thickness of insulated glazing unit made of louvered polycarbonate	16 mm
Weighted sound absorption factor	22 dB
Panel height is dynamically calculated on the basis of doorway height:	maximum value - 650 mm, minimum value - 370 mm
Maximum doorway width without lintel	3190 mm
Maximum doorway width with lintel	6000 mm
Maximum panel section height	8000 mm



Composite panel

The composite panel consists of 2 aluminium plates with foamed polyurethane filler between them.



One can imbed a pass door from the material similar to the door leaf into all DoorHan industrial doors – sectional doors ISD 01, panoramic doors ISD 02.



PASS DOOR HANDLE



All DoorHan pass doors are equipped with a mortise lock and a handle. Simple and fine form of the handle makes it not only convenient, but also attractive by its design.

STEP-HANDLE



The step-handle is an important and necessary component of any doors. The step-handles for DoorHan industrial doors have a special ergonomic form. The step-handle is a refined object, which will decorate any doors. DoorHan handles are developed so, that when you lift the door leaf manually, you spend less strength.

PASS DOOR DIMENSIONS:

Width: 800 mm
Height: 1800 mm or 1900 mm
Minimum door leaf height: 2130 mm
Minimum distance from doorway edge to pass door: 1000 mm (when pass door is imbedded asymmetrically)
Pass door sill height: 75 mm (without seal)

DOOR HANDLE



DoorHan handles are ergonomic and easy-to-use; they are developed taking into account modern design solutions. We offer handles, which will be ideal for doors of any type. The handles are developed so, that they will not freeze at low temperatures and will serve for a long time.

LATCH LOCK



The latch lock is one of the most reliable devices for fixing doors in a closed position. The latch lock is a significant obstruction during a prying attack during. The latch lock with dual control is made of high-quality steel that increases its reliability.



OPEN PASS DOOR SENSOR



The magnetic noncontact open pass door sensor is designed for preventing the drive start, when pass door is open. When pass door opens, a magnet and a readout device move relative to each other, a contact opens, and the control unit prevents the drive start.

DOOR CLOSER



The door closer is an accessory, which considerable facilitates the pass door use. The attachment of the sliding door closer in DoorHan pass door is performed in firm steel reinforcement.

VARIETY OF SOLUTIONS AND FUNCTIONALITY

INDUSTRIAL SECTIONAL DOORS
ISD01, ISD02

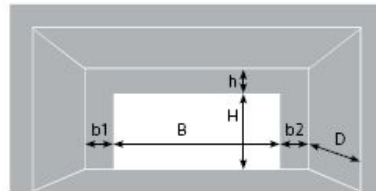

DIMENSIONS

H - opening height (distance from floor to opening top) 2 - 8 m;
B - opening width (distance from left edge to right opening) 2 - 7 m, during vertical lift - up to 8 m;
h - lintel (distance from opening top to ceiling) minimum 150 mm (various types of tracks are used depending on the lintel value);
b1 and **b2** - distances from opening edge to lateral interior wall minimum 130 mm;
D - garage depth (distances from opening to distant interior garage wall) more than $H + 500$ mm.

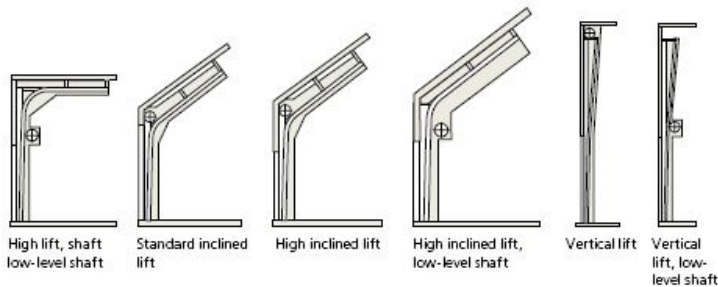
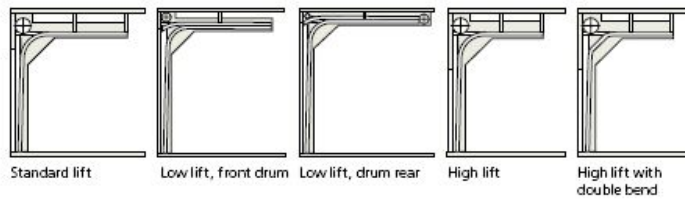

SAFETY CONCEPT AND CONSTRUCTION

PROTECTION AND RELIABILITY



Cable break safety device.
When the cable is broken or when there is an attempt to lift the doors without authorization, the device engages the strip, mounted on the door leg. At the same time the leaf is blocked. Consequently, the doors fall or their unauthorized lift is prevented.

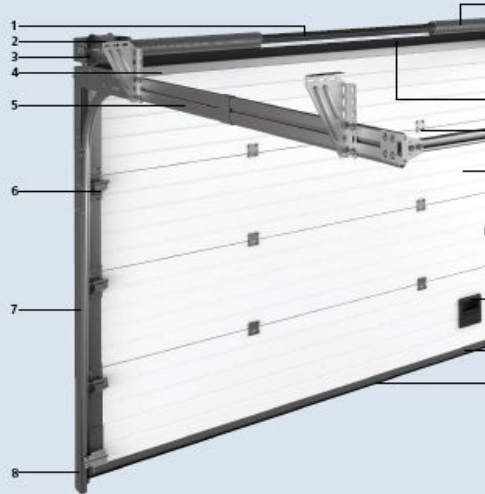

09

Sectional door construction

1. Connecting coupling
2. Shaft
3. Drums
4. U-type end support bracket
5. Top section
6. Tracks for door leaf
7. Adjustable bracket with rollers
8. Vertical angle
9. Bottom cover
10. Torsion mechanism
11. Spring break safety device
12. System for attaching horizontal tracks to ceiling
13. Electric shaft operator Shaft-30
14. Special stops
15. Top seal
16. Hinges
17. Door leaf made of sandwich panels
18. Lock
19. Side cover
20. Handle
21. Bottom bracket with "cable break safety device"
22. Bottom section
23. Bottom seal

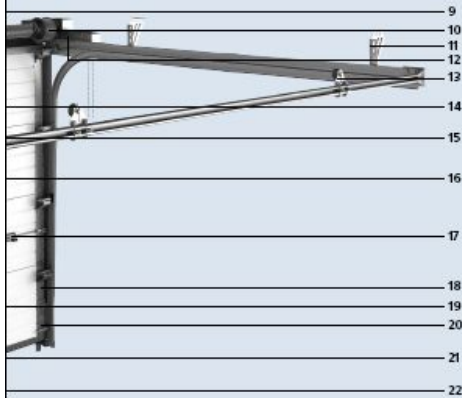

The cable break safety mechanism is mounted as an upper bracket on the leaf. In case of cable failure the protection mechanism stops the door leaf motion, fixing in the track.



DoorHan innovation - anti-finger trapping devices - special plastic strips, which prevent fingers from being trapped in a gap between rollers and the track.

TORSION MECHANISM



The enhanced requirements to operational safety and reliability are imposed on the industrial doors. DoorHan offers an innovative solution – a torsion mechanism. The torsion mechanism consists of a spring, a spring break safety device and a connecting coupling. The torsion mechanism spring is raised so, as the door leaf, if it is lowered or lifted, hovers, without falling down and without moving upwards. The torsion mechanism with an octagonal shaft for the industrial doors and the U-type bracket allows you to mount the structure without the installation of additional attachment lintels. DoorHan adjustable coupling has a number of advantages. Owing to its structure it is possible to adjust the cable tension; the distance between U-type brackets increases; the possibility of shaft component disconnection is excluded. The torsion mechanism is delivered in the assembled condition that considerably eases its installation.

COMPANY MANUFACTURING AND STORAGE NETWORK



DOORHAN

- ✓ Door systems
- ✓ Roller shutter systems
- ✓ Warehouse systems
- ✓ Aluminium systems
- ✓ Fire door systems
- ✓ Automatics systems

For additional information, please contact our representatives.



www.doorhan.com